

Inferno MP9e Setup Sheet

Arn0 at Petitr.com

ver.1.05

Driver: _____ Date: _____ Event: _____ Track: _____

Track condition: Smooth / Bumpy / Dry / Wet Traction: Low / Medium / High
Blue Groove / Clay / Dirt / Dusty / Grass / Sandy / Loose / Loomy

Front tyre: _____ Rear tyre: _____
Front ride height: _____ Rear ride height: _____

Motor: _____
ESC: _____
ESC Setting: _____
Pinion / Spur: _____
Battery: _____

●ダンパーセッティング / Shock-Set-Up

	FRONT	REAR
ダンパータイプ Shock Type		
ダンパーピストン Shock Piston	<input type="checkbox"/> φ 1.2x6B <input type="checkbox"/> φ 1.2x8B <input type="checkbox"/> φ 1.2x8T <input type="checkbox"/> φ 1.3x5B <input type="checkbox"/> φ 1.3x6W <input type="checkbox"/> φ 1.3x8W <input type="checkbox"/> φ 1.3x8T <input type="checkbox"/> φ 1.4x5W <input type="checkbox"/> φ 1.4x8T	<input type="checkbox"/> φ 1.2x6B <input type="checkbox"/> φ 1.2x8B <input type="checkbox"/> φ 1.2x8T <input type="checkbox"/> φ 1.3x5B <input type="checkbox"/> φ 1.3x6W <input type="checkbox"/> φ 1.3x8W <input type="checkbox"/> φ 1.3x8T <input type="checkbox"/> φ 1.4x5W <input type="checkbox"/> φ 1.4x8T
オイル Oil	#	#
スプリング Spring		
プレッシャースポンジ Pressure Sponge		

B = Black
W = White
T = Taper

●車高/Ride Height

FRONT	REAR
mm	mm

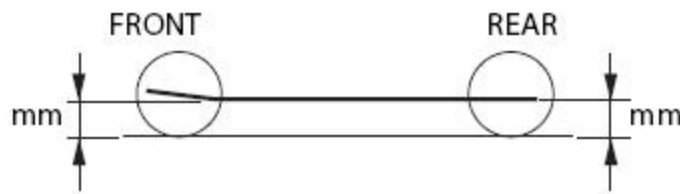

●リバウンド高/Rebound ●キャンバー角/Camber Angle

FRONT	REAR
mm	mm

FRONT	REAR
+ °	+ °
- °	- °

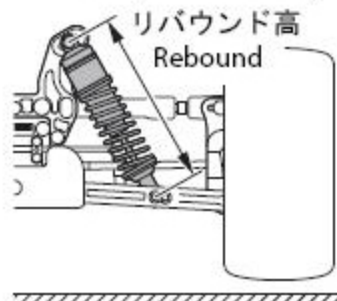

+ Positive Camber
- Negative Camber

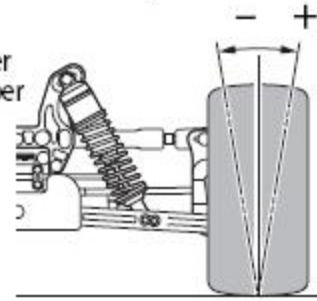

●フロントスキッド角 / Front Skid Angle

上部 Upper	フロント側 Front Side	<input type="checkbox"/> <input type="checkbox"/> <input type="checkbox"/> <input type="checkbox"/> <input type="checkbox"/> <input type="checkbox"/>
	リヤ側 Rear Side	<input type="checkbox"/> <input type="checkbox"/> <input type="checkbox"/>
下部 Under	フロント側 Front Side	<input type="checkbox"/> 9°L <input type="checkbox"/> 11°L <input type="checkbox"/> 9°S <input type="checkbox"/> 11°S

●アッパーアームポジション / Upper Arm Position

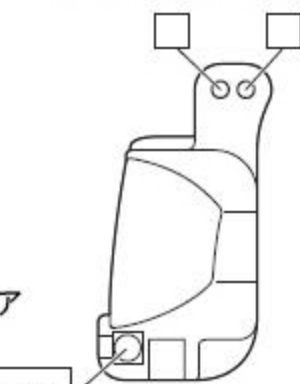

●フロントトレッド / Front Tread

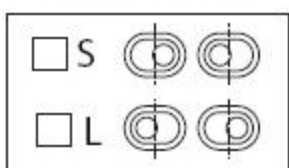

●フロントハブキャリア / Front Hub Carrier

<input type="checkbox"/> -1° <input type="checkbox"/> 0° <input type="checkbox"/> +1°
<input type="checkbox"/> Plastic <input type="checkbox"/> Aluminum

●ダンパー取り付け位置 / Shock Mount Position

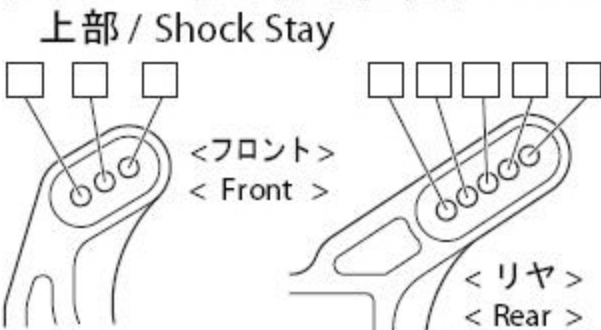

下部 / Sus Arm	
FRONT	REAR
<input type="checkbox"/> In <input type="checkbox"/> Out	<input type="checkbox"/> In <input type="checkbox"/> Out
Rear Shock Stay	
<input type="checkbox"/> SHORT	<input type="checkbox"/> LONG

●デフセッティング / Diff Gear Set-Up

	FRONT	CENTER	REAR
オイル Oil	<input type="checkbox"/> Normal <input type="checkbox"/> LSD	<input type="checkbox"/> Normal <input type="checkbox"/> LSD	<input type="checkbox"/> Normal <input type="checkbox"/> LSD

●トー角 / Toe Angle

FRONT	REAR
+ °	<input type="checkbox"/> 2° <input type="checkbox"/> 2.5° <input type="checkbox"/> 3°
- °	

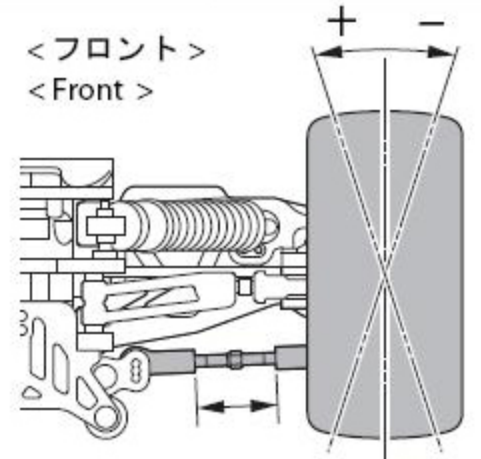

●ホイールベース / Wheelbase

Wheelbase	
リヤハブカラー Collar of Rear Hub	Front Side _____ mm Rear Side _____ mm

●リヤロールセンター&スキッド角 / Rear Roll Center & Skid Angle

< ロールセンターH > < Roll Center H >



< ロールセンターL > < Roll Center L >



●アッパーアームポジション / Upper Arm Position

	REAR
パルク側 Shock Stay	<input type="checkbox"/> 1 <input type="checkbox"/> 2 <input type="checkbox"/> 3 <input type="checkbox"/> 4 <input type="checkbox"/> 5 <input type="checkbox"/> 6 <input type="checkbox"/> 7 <input type="checkbox"/> 8
ホイール側 Wheel side	<input type="checkbox"/> 1 <input type="checkbox"/> 2 <input type="checkbox"/> 3 <input type="checkbox"/> 4 ※3, 4は1FW410使用時

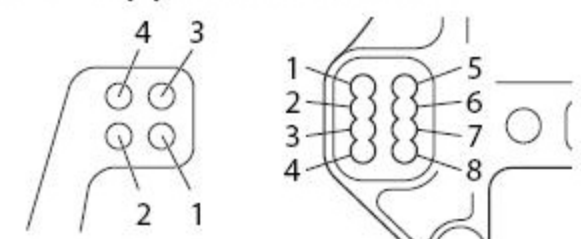

●リヤハブキャリア / Rear Hub Carrier

<input type="checkbox"/> Plastic <input type="checkbox"/> Hard
<input type="checkbox"/> Aluminum
<input type="checkbox"/> Aluminum /Off-2.0

●ステアリングプレート / Steering Plate

<input type="checkbox"/> A <input type="checkbox"/> B <input type="checkbox"/> C	<input type="checkbox"/> F↑ <input type="checkbox"/> F↓
--	--

●リヤハブポジション / Rear Hub Position

<input type="checkbox"/> Upper <input type="checkbox"/> Under

●トルクロッド / Chassis Brace

FRONT	REAR
<input type="checkbox"/> Plastic	<input type="checkbox"/> Plastic
<input type="checkbox"/> Aluminum	<input type="checkbox"/> Aluminum

●スタビライザー / Anti Roll Bar

FRONT	REAR
φ	φ
mm	mm

< フロント > < リヤ >
< Front > < Rear >

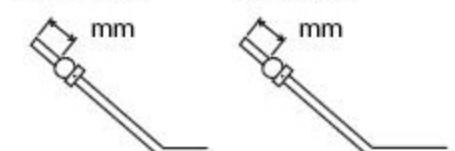

●リヤトレッド / Rear Tread

フロント側 Front Side	リヤ側 Rear Side
<input type="checkbox"/> S <input type="checkbox"/> M <input type="checkbox"/> L	<input type="checkbox"/> S <input type="checkbox"/> M <input type="checkbox"/> L

●ウイング角度 / Wing Angle

<input type="checkbox"/> Upper <input type="checkbox"/> Under

●ホイールハブ / Wheel Hub

FRONT	REAR
<input type="checkbox"/> NARROW <input type="checkbox"/> NORMAL	<input type="checkbox"/> NARROW <input type="checkbox"/> NORMAL

●ウエイト / Weight

